

# FLAT ROOF BOX SPAN CARPORTS

AGS/NC/03

*Thank you for choosing this quality product. We strongly recommend that you read these instructions thoroughly. Please take your time and do not rush the erection of your new Carport and you will ensure a finished product of which you may be justly proud.*

Due to the large range of sizes and styles available, it is impossible to prepare an instruction manual for each individual size and model. The following instructions relate to a 6m wide and 6m long carport. This manual is a guide only and should be used in conjunction with the components list and engineers plans as submitted to council.

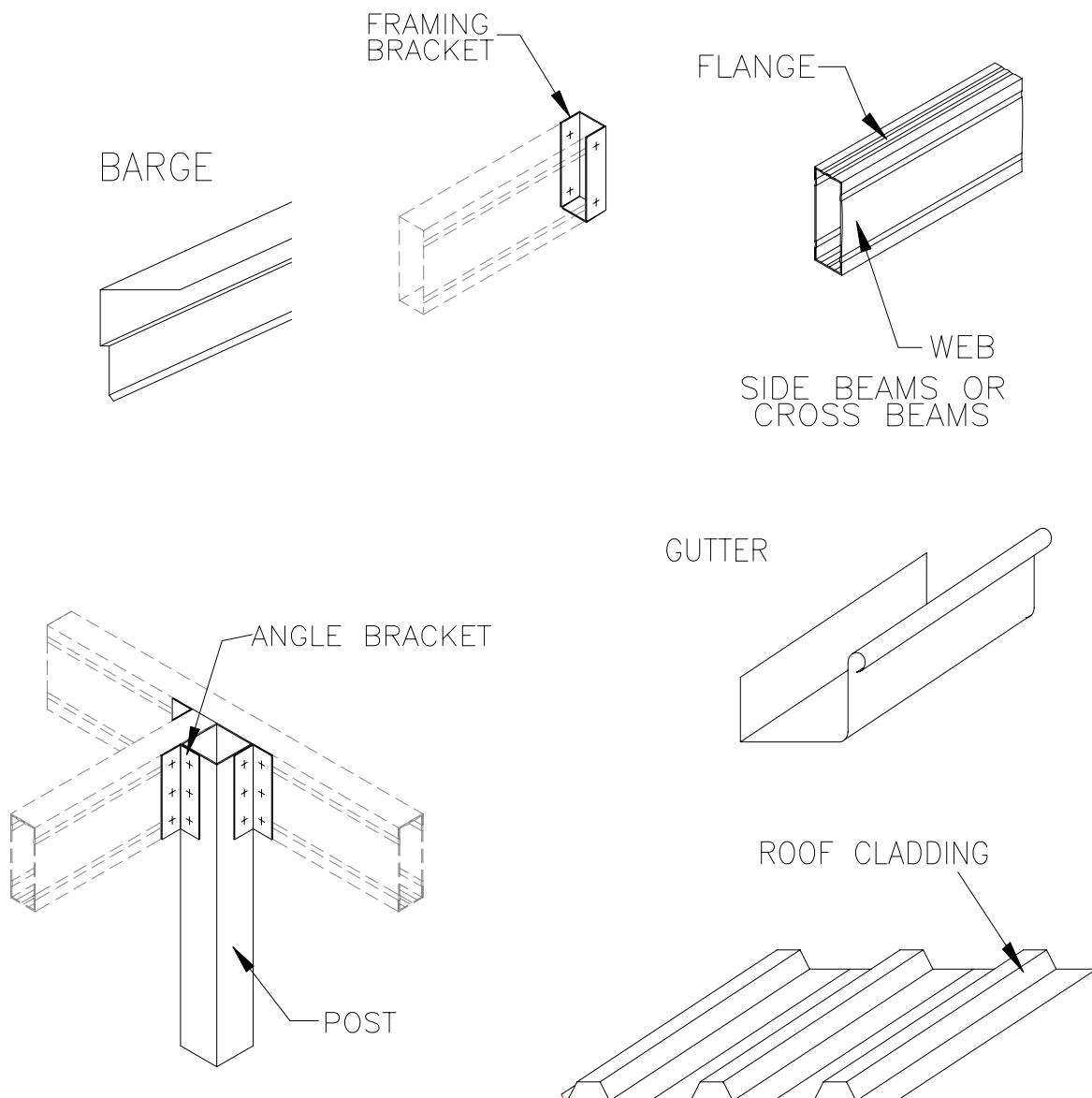

## Step 1 – Footings

Set out the location of the pads to be excavated and ensure they are square by checking the diagonal measurements. Dig out and pour concrete pads. Note- the carport can also be fixed to a suitable concrete slab or erected into footing holes, then concrete poured.

Important note; Please leave the pegs and strings marking the perimeter of the building in place until the position of base connectors is clearly marked.

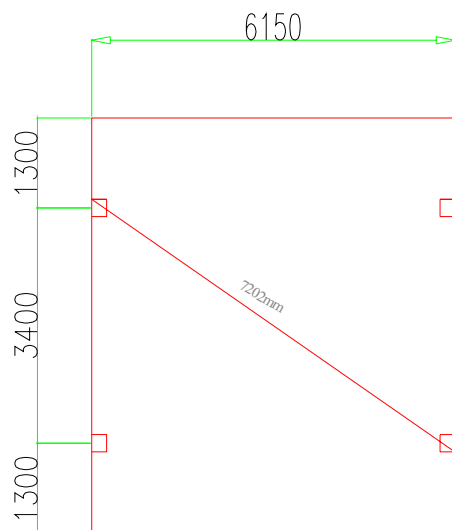

6m WIDE x 6m LONG FLAT CARPORT

**ALWAYS CHECK YOUR COMPONENTS LIST TO ENSURE THE CORRECT PART, LENGTH, QUANTITY AND LOCATION. IF IN DOUBT PLEASE CONTACT YOUR SUPPLIER.**

## Step 2 - Preparation of carport posts

Check levels of footings and cut posts accordingly ensuring adequate fall for rainwater run off, this detail will vary depending on location, building size and roof cladding type.

Set out and bore two 12mm holes at the bottom of the carport posts, as per the following drawing. Holes at bottom of post are only required if posts are to be dynabolted to concrete.

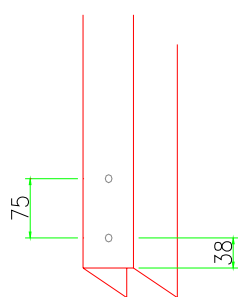

Base of Post

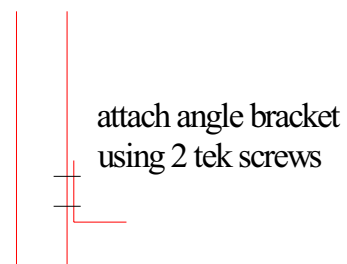

Base of Post to be set in concrete

## Step 3 \_ Fixing of Base Connectors

The base connectors will have 2 or 4 holes for sleeve anchors depending on the size of the carport.

Using the string line marking the buildings perimeter mark the position of each post, the distance in from each side is equivalent to the flange width of the side beams.

Using sleeve anchors supplied fix base connectors to concrete footings.

The position along the side wall, and distance between columns will vary depending on the buildings size and the number of columns being used.

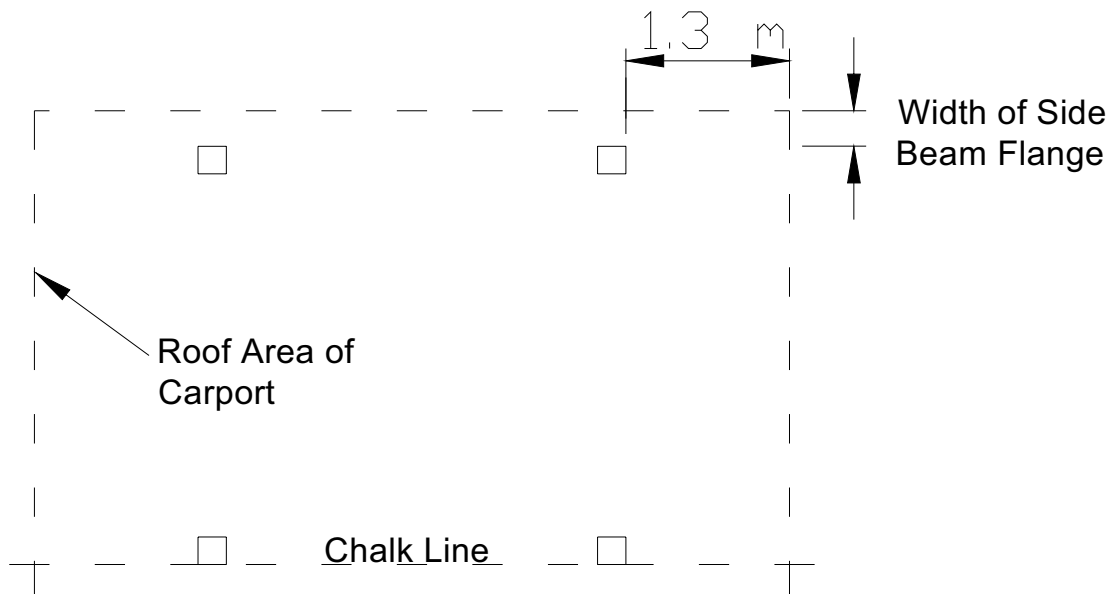

### Step 4 – Preparation of side carport beams

On the web side of the side carport beams (usually the 2 longest Beams) set out and attach the framing brackets with 4 tek screws. The end brackets are to be fitted flush to the ends of the side beam. Set out and screw the angle brackets to the side beam for connection of the post (place only 1 tek screw into bracket).

Cross beam spacings =   Corrugated   1.2m max spacing  
                                   Monoclad     1.7m max spacing

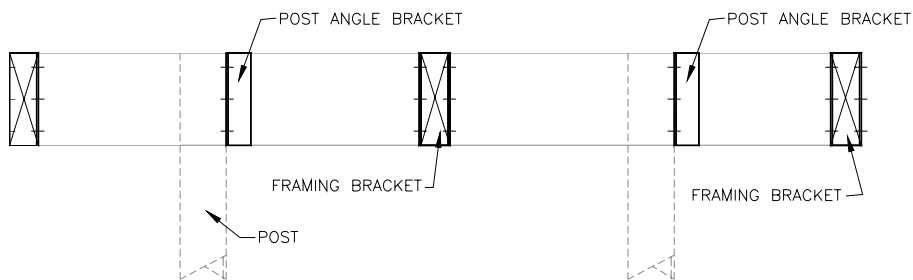

### Step 5 – Assemble and stand the carport post and the side carport beams

Connect the side beams to the carport posts by using the post angle bracket supplied, with 3 framing screws through the bracket into the post. Stand post in footing holes or slip the columns over the base connectors. Plumb the column and hold in place by using temporary bracing. Put an extra 2 tek screws through the angle bracket to the side beam. Drill holes through base connectors, fit 2 bolts per post and tighten. Repeat this step to erect the other side carport beams.

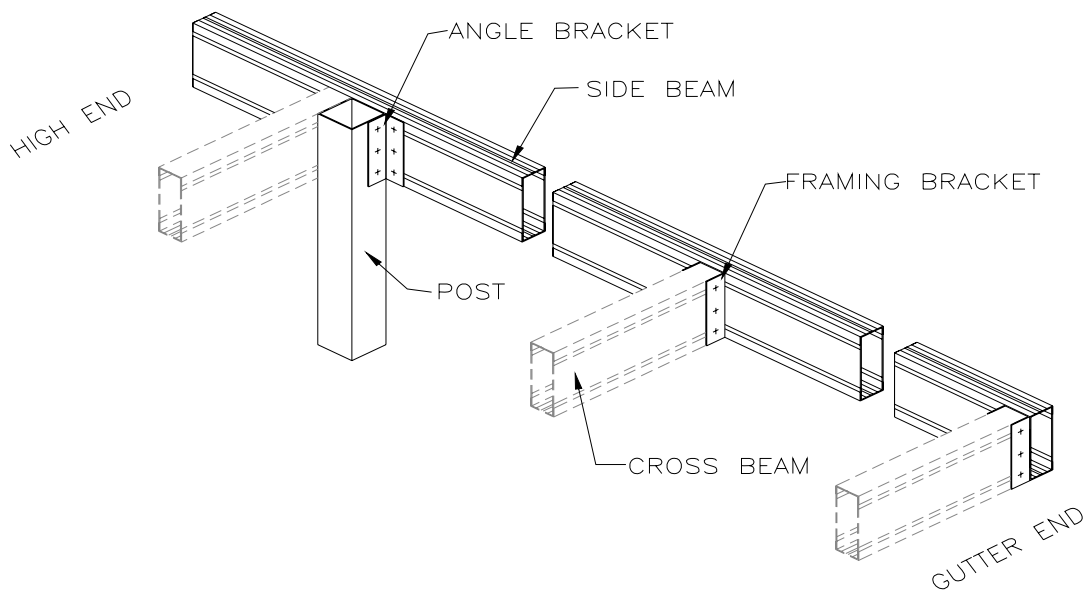

### Step 6 – Fit the carport cross beam

Screw an angle bracket to each end of two cross beams (as shown below). Place one cross beam in position at the front posts and attach it to the side beam using 1 frame screw each end, repeat this step at the rear pair of posts.

Check posts for plumb and then add another two screws to every connection.

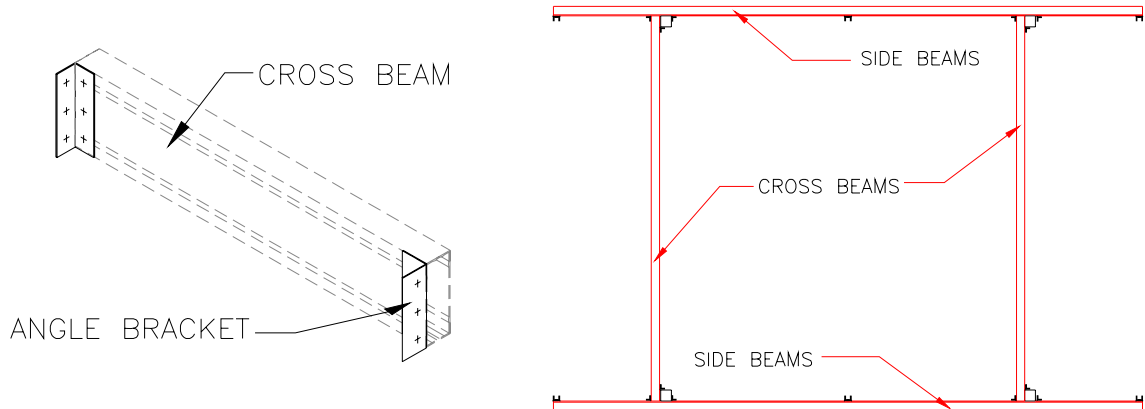

PLAN OF ROOF FRAME AT STEP 6

### Step 7 – Fit the remaining cross beams

Using frame screws, fit the remaining carport beams to the framing brackets fitted to the side beams.

### Step 8 – Square up the carport frame

If the previous steps have been completed correctly the frame will be plumb and square. This is done by checking the diagonals are equal as indicated in the diagram below, or can be calculated by using this simple formula. Diagonal = square root ( $\text{length}^2 + \text{width}^2$ ).

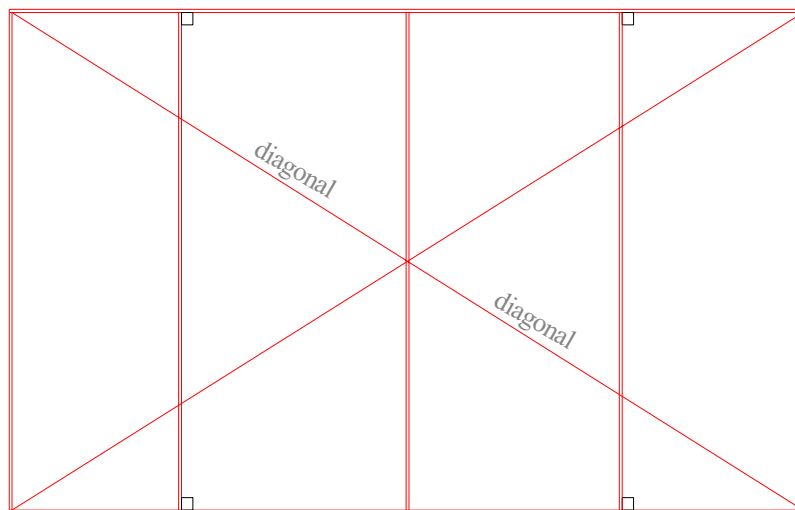

CHECK DIAGONALS ARE EQUAL

### Step 9 – Fit triangular knee braces

2 x triangular knee braces are to be fitted to each post, 1 from the post to the side beam and 1 from the post to the cross beam.

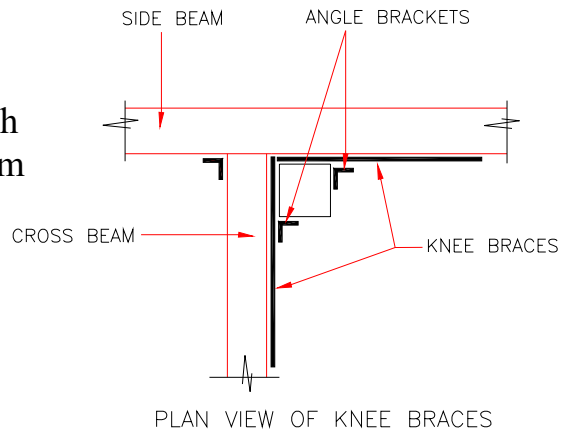

### Step 10 – Fit roof sheeting

Lay the first sheet in position ensuring that the roof sheet is flush with the outer edge of the front rafter. This edge should be pan fixed using 10-16 wall screws to aid the fitting of barge capping. If the frame is square the first sheet should now be flush along the length of the side beam. You may need to move sheet slightly before fixing off the first sheet. All other sheets may now be fitted, If possible do not stand on the roof while fixing roof cladding.

### Step 11 – Fit gutters and cappings

Remove plastic cover protecting colorbond cappings and flashings before the capping or flashing is fitted.

- a) Fit the stop ends and nozzle to the guttering
- b) Fit gutter brackets to the Cross Beam using pop rivets. Ensure the brackets are fitted at 1.0m spacings maximum using a string line to ensure required fall.
- c) Fit the guttering into the gutter brackets
- d) Fit side and head barge capping ensuring the bottom edge of the flashing is fixed to the Box Span Beams using pop rivets.

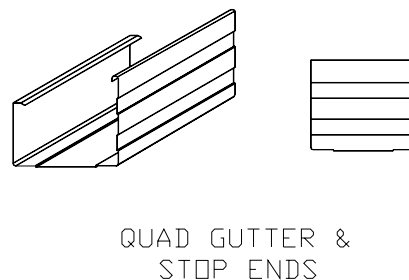
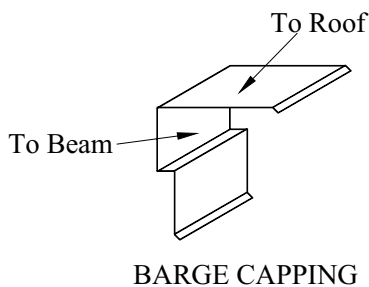

### **Step 12 – Cut and fit downpipes**

Cut and fit the downpipes to the drainage system.

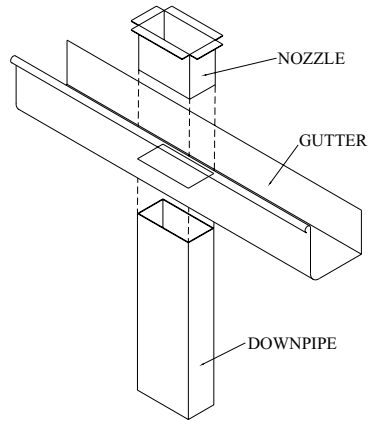

STANDARD DRAINAGE CONECTION

### **Step 13 – Finish**

Remove any temporary bracing and check all the required bolts and tek screws are fitted and tightened.

**BRUSH COMPLETE CARPORT DOWN WITH A SOFT BROOM TO REMOVE ANY METAL DUST/FILINGS CAUSED BY ANGLE GRINDER.**

***CONGRATULATIONS ON A JOB WELL DONE!***